

User Manual

Xtreme LV 1.0

A12 VERSION

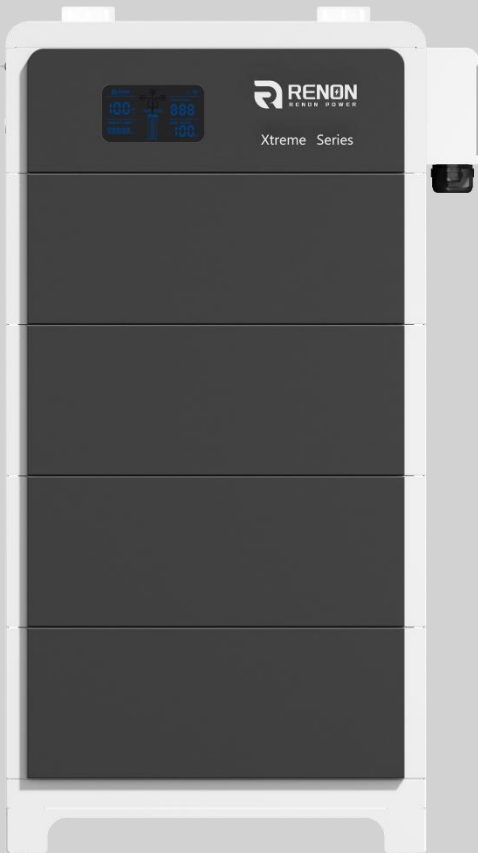

E-mail: support@renonpower.com

Website: www.renonpower.com

Renon Power Technology Inc.

© Renon Power Technology Inc.
All Rights Reserved Specifications are subject to change without notice.



Renon Power

We Care About Sustainability

With our own R&D team and automatic production factory, we are dedicated to delivering innovative, reliable, and affordable energy storage solutions to global customers.

At Renon, we believe that sustainable energy is the future. We are passionate about reducing carbon emissions and preserving our planet for future generations. That's why we invest heavily in research and development, leveraging the latest technologies to design and manufacture energy storage systems that are efficient, scalable, and adaptable.

Our products are designed to meet the needs of a wide range of applications, from residential and commercial buildings to industrial facilities and utility-scale projects. Whether you're looking to reduce your energy bills, increase your energy independence, or support your sustainability goals, Renon has the right solution for you.

Our commitment to quality and customer satisfaction is unwavering. We work closely with our clients to understand their unique needs and provide customized solutions that meet or exceed their expectations. We also provide comprehensive technical support, maintenance, and warranty services to ensure that our customers get the most out of their investment.

JOIN US ON OUR MISSION TO MAKE RENEWABLE ENERGY WITHIN REACH.

**PROVIDE INNOVATIVE,
RELIABLE, AND
AFFORDABLE ENERGY
STORAGE SOLUTIONS
TO CUSTOMERS**



Table of Contents

1 Safety Instructions	5
1.1 General Safety Precautions	5
1.2 Transportation and Storage Precautions	5
1.3 Installation Precautions	6
1.4 Usage Precautions	7
1.5 Response to Emergency Situations	7
1.6 Qualified Personnel	8
2 Preparation before Installation	9
2.1 Safe Handling Guide	9
2.1.1 Familiar with the Battery	9
2.1.2 Precautions	9
2.1.3 Tools	9
2.1.4 Safety Gear	10
2.2 System Premeasurement	10
2.3 Installation location	10
2.4 Package Items	11
3 Installation	14
3.1 Device Installation	14
3.2 Connection	17
3.3 Application scenarios	20
3.3.1 Single Stack	20
3.3.2 Parallel	21
3.3.3 Precautions for Multiple Parallel Connections	21
4 Cloud Platform Configuration	24
5 Battery Specifications	32
5.1 Product Features	32
5.2 Specifications	33
5.2.1 Specifications 1 (16 series cells)	33
5.2.2 Specifications 1 (15 series cells)	34

5.3 Interface Information	35
5.3.1 Power Button	35
5.3.2 WiFi Antenna Port7	36
5.3.3 Inverter Dial Switch	36
5.3.4 Address Dial Switch	37
5.3.5 Function Dial Switch	38
5.3.6 Inverter Communication Port	39
5.3.7 Debug Port	39
5.3.8 INVERTER 1 Port (RJ45)	40
5.3.9 INVERTER 2 Port (RJ45)	40
5.3.10 Parallel Communication Port A & B	41
5.3.11 Power Negative &Positive	41
5.3.12 Dial Code Switch	41
5.4 LCD Screen	44
5.4.1 SOC, SOH and Upgrading State	45
5.4.2 Version and Accumulated Discharge Energy	45
5.4.3 ESS Status, Power, and Voltage	45
5.4.4 Battery Operation Status	45
5.4.5 Screen Display Code	46
6 Troubleshooting & Maintenance	50
6.1 Regular Maintenance	50
6.2 Troubleshooting	50
6.3 Status Code	52
6.3.1 Warning Codes	52
6.3.2 Error Codes	54
6.3.3 Protection Codes	57

1 Safety Instructions

For safety reasons, installer and user are responsible for familiarizing themselves with the contents of this document and all warnings before installation and usage.

1.1 General Safety Precautions

- Please carefully read this manual before any work is carried out on the product, and keep it located near the product for future reference.
- All installation and operation must comply with local electrical standards.
- Please ensure the electrical parameters of the product are compatible to related equipment.
- Do not open or dismantle the battery module. Electrolyte is very corrosive. In normal working conditions contact with the electrolyte is impossible. If the battery casing is damaged, do not touch the exposed electrolyte or powder because it is corrosive.
- The electronics inside the product are vulnerable to electrostatic discharge, keep it away from that.
- Do not place items or tools on the product.
- Do not damage the product by dropping, deforming, impacting, cutting.
- Keep the product away from liquid. Do not touch the product if liquid spills on it. There is a risk of electric shock.
- Do not expose the product to flammable or harsh chemicals or vapors.
- Do not paint any part of the product, include any internal or external components.
- Do not change any part of the product, especially the battery and cell.
- Besides connection under this manual, any other foreign object is prohibited from being inserted into any part of the product.
- The warranty claims are excluded for direct or indirect damage due to items above.
- Batteries must not be mixed with domestic or industrial waste.
- Batteries marked with the recycling symbol must be processed via a recognized recycling agency. By agreement, they may be returned to the manufacturer.

1.2 Transportation and Storage Precautions

- The batteries must be transported according to UN3480, they must be packed according to packaging requirements of Special Regulation 230 of IMDG CODE (40-20 Edition) for maritime transport, and P965 IA for air transport (SOC less than 30%). The original packaging complies with these instructions.

- If the product needs to be moved or repaired, the power must be cut off and completely shut down.
- The product must be transported in its original or equivalent package; the battery module must be placed at upright position.
- The modules are heavy. Ensure adequate and secure mounting and always use suitable handling equipment for transportation.
- If the product is in its package, use soft slings to avoid damage.
- Do not stand below the product when it is hoisted.
- During transportation, severe impact, extrusion, direct sunlight, and rain should be avoided.
- Store in a cool and dry place.
- Store the product in clean environment, free of dust, dirt, and debris.
- Store the product out of reach of children and animals.
- Don't store the battery under 50% SOC for over one month. This may result in permanent damage to the battery and void the warranty.
- During long term storage, it is required to charge the battery module every 3 months, and the SOC should be no less than 90%.

1.3 Installation Precautions

- Do not install the product in an airtight enclosure or in an area without ventilation.
- Do not install the product in living areas of dwelling units or in sleeping units other than within utility closets and storage or utility spaces.
- If the product is installed in a garage or carport, ensure there is adequate clearance from vehicles.
- While working on the product wear protective eyeglasses and clothing.
- Handle the battery wearing insulated gloves.
- Use insulated tools. Do not wear any metallic items such as watches, bracelets, etc.
- Turn-off related circuit breakers before and during the installation to avoid electric shock.
- Do not connect any AC conductors or photovoltaic conductors directly to the battery pack. These are only to be connected to the inverter.
- Wiring must be correct, do not mistake the positive and negative cables, and ensure no short circuit with the external device.
- Over-voltages or wrong wiring could damage the battery pack and cause combustion which can be extremely dangerous.
- Make sure the product is well grounded, and comply with local specifications, the recommended grounding resistance is less than 1Ω.
- Handle with care because Li-ion Battery is sensitive to mechanical shock.

1.4 Usage Precautions

- Before starting the system, the operator should strictly check the connection terminals to ensure that the terminals are firmly connected.
- If there's a circuit breaker between battery and inverter, the breaker is supposed to be on before powering on the battery.
- Do not open the product, connect, or disconnect any wires when it's working to avoid electric shock.
- Battery needs to be recharged within 12 hours after fully discharging.
- The default temperature range over which the battery can be discharged is -4°F (-20°C) to 122°F (50°C). Frequently discharging the battery in high or low temperature may deteriorate the performance and life of the battery pack.
- The default temperature range over which the battery can be charged is 32°F (0°C) to 122°F (50°C). Frequently charging the battery in high or low temperature may deteriorate the performance and life of the battery pack.
- Do not charge or discharge a damaged battery.
- Please contact the supplier within 24 hours if there is something abnormal.

1.5 Response to Emergency Situations

- Damaged batteries are dangerous and must be handled with extreme care. They are not suitable for use and may cause danger to people or property. If the battery pack appears to be damaged, place it in the original container and return it to an authorized dealer.
- If the battery pack is wet or submerged in water, do not allow anyone to touch the water, and then contact authorized dealer for technical support.
- In case of fire, use carbon dioxide, FM-200 or ABC dry powder fire extinguisher; if possible, move the battery pack to a safe area before it catches fire.
- If a user happens to be exposed to the internal materials of the battery cell due to damage on the outer casing, the following actions are recommended.
- In case of inhalation: Leave the contaminated area immediately and seek medical attention.
- In case of contact with eyes: Rinse eyes with running water for 15 minutes and seek medical attention.
- In case of contact with skin: Wash the contacted area with soap thoroughly and seek medical attention.
- In case of ingestion: Induce vomiting and seek medical attention.

1.6 Qualified Personnel

The installation guide part described herein is intended for use by skilled staff only. Skilled staff is defined as a trained and qualified electrician or installer who has all the following skills and experience:

- Knowledge of battery specification and properties.
- Knowledge of the installation of electrical devices.
- Knowledge of torsion and screwdrivers for different types of screws.
- Knowledge of local installation standards.
- Electrical license for battery installation required by the country or state.
- Knowledge of the dangers and risks associated with installing and using electrical devices and acceptable mitigation methods.
- Knowledge of and adherence to this guide and all safety precautions and best practices.
- For safety reasons, installers are responsible for familiarizing themselves with the contents of this document and all warnings before performing installation and usage.

2 Preparation before Installation

2.1 Safe Handling Guide

2.1.1 Familiar with the Battery

Be careful when unpacking the system. Every module of the product is heavy. Don't lift them with a pole. The weight of the modules can be found in the chapter "**Specifications**".

Familiar with battery. The battery poles are located on the top and bottom sides of the battery module. It's designed of fast mount and foolproof, no need to recognize the positive and negative poles, but take care of them especially the bottom one.

2.1.2 Precautions

Before installation, be sure to read the contents in chapter "**Safety Precautions**", which is related to the operation safety of installation personnel, please pay attention to it.

2.1.3 Tools

The following tools are required to install the product:



Drill

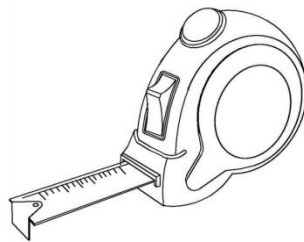

Tapeline



Pencil or marker

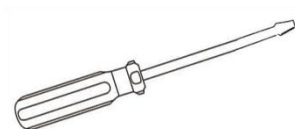

Straight screwdriver

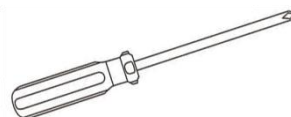

Phillips screwdriver

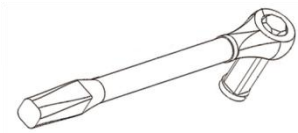

Torque wrench

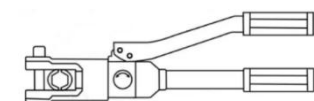

Hydraulic clamp

Use properly insulated tools to prevent accidental electric shock or short circuits. If insulated tools are not available, cover the entire exposed metal surfaces of the available tools, except their tips, with electrical tape.

2.1.4 Safety Gear

It is recommended to wear the following safety gear when dealing with the product:



Insulated gloves



Safety goggles



Safety shoes

2.2 System Premeasurement

The battery required adequate clearance for installation and airflow. The minimum clearance for system configuration is given below. The cable connected between battery pack and inverter should be in accordance with the installation guide or manual of the inverter.

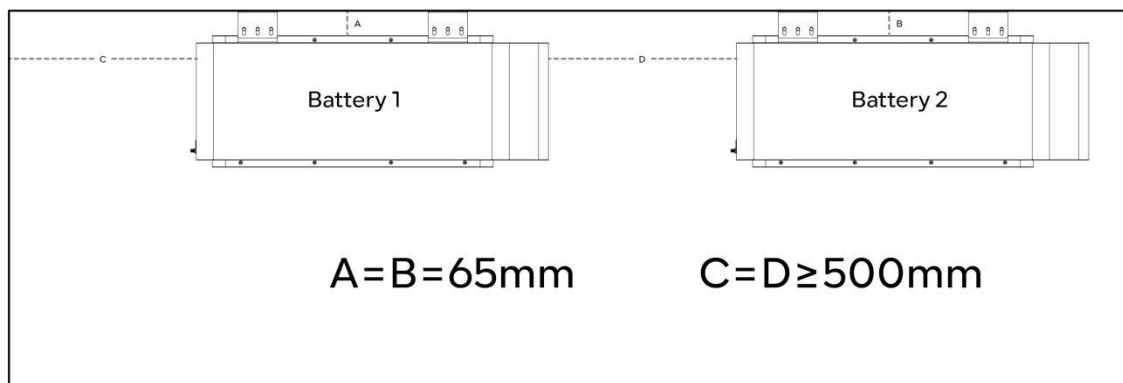

Figure 2.2.1. System clearance

2.3 Installation location

Make sure that the installation location meets the following conditions:

- The floor is flat and level.
- The surface of the wall is smooth and perpendicular to the ground, which can bear the weight.
- The area is completely water proof.
- The area shall avoid direct sunlight.
- There are no flammable or explosive materials.
- The distance from heat source is more than 80inch(2m).









- The ambient temperature is within the range from 32°F (0°C) to 95°F (35°C).
- The humidity is maintained at a constant level.
- There is minimal dust and dirt in the area.
- Avoid installation in an area confined or with high salinity.
- Do not install outside directly.
- Do not place in an area accessible to children or pets.







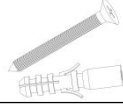









2.4 Package Items

After receiving the product, please unpack the boxes, and check product and packing list first, if product is damaged or lacks parts, please contact the local retailer.



Here is the Xtreme Series Packing List:

(1) Main Controller:

No.	Item	Specification	Qty	Usage	Diagram
1	Main Controller	R-MC300-XTL01	1	Controller of the battery cluster	
2	Base	25.0*9.4*5.7inches /635*238*145mm	1	Bottom base of the battery cluster	
3	Mounting A	3.1*1.6*0.9inches /80*40*22mm	2	Mounted at the rear of the controller, used to stabilize the cluster	
4	Mounting B	3.1*2.2*1.2inches /80*55*30mm	2	Combines the Mounting A to wall, used to stabilize the cluster	
5	Screw	Stainless steel M4*12 triple combination	8	Fastens Mounting A to controller, fix the side panel connector to the bottom base	
6	Screw	Stainless steel M6*16 triple combination	6	Fastens Mounting B to A	
7	Allen	M4	1	Tightens the screws on the side cover of the main controller	
8	Screw	Plastic expansion screw M10*60	6	Fastens Mounting B to wall	
9	Screw	M4x10, hexagon socket head cap screw, 304 stainless steel	8	Side plate fixing screws	
10	Screw	Stainless steel expansion screw M8*80	4	Fastens base to floor	

11	WIFI	2.4/5GHz L-type	1	Connects with internet	
12	OT Terminal (Optional)	SC120-8	2	Crimps power wire	
13	OT Terminal (Optional)	SC70-8	4	Crimps power wire	
14	Communication Cable	RJ45 network cable T568B, 2m	1	Communicates between clusters when parallel	
15	Inverter Communication Box and Cable (Optional)	Standard RJ45 network cable , 200mm	1	Communicates with specified inverter	
		RJ45 network cable T568B, 2m	1	Communicates with inverter	
		3.3*1.0*0.9inches /85*26*22mm	1	Sets the pin order of the communication cable of battery and inverter, cooperate with 2 standard network cable	
16	User Manual	Xtreme LV series	1	User manual	
17	Main Control Layer	163x26, Aluminum, T=4.5	2	Main control sides	
18	Base Layer	163x15, SPCC, T=2.0	2	Aluminum board sides	
19	Busbar (optional)	T2red copper, nickel plating,64x48x3, T=3mm, pitch-row27.5,2circular hole, M8 swage nut	2	Output busbar	
20	Screw(optional)	M8x18, philips, outer hexagon, carbon steel with blue zinc	2	Busbar installation	
21	Match Inverter System Labels	108x62mm	1	Sticks on the actual corresponding position of inverter	
22	Match Sol-Ark Inverter System Small Labels	38x35mm	1	Sticks on the master side panel cover	
23	Quick Installation Manual	Xtreme LV series	1	User manual	
24	Inverter Communication Cable(optional)	RJ45 network cable	1	Connects with inverter	

(2) Battery Module:

No.	Item	Specification	Qty	Usage	Diagram
1	Battery Module	25*9.4*5.7inches/ 635*238*145cm	1	Storage of cells	
2	Screw	M4*10 screws with collar	4	Side plate fixing screws	
3	Side plate	9.5*6.5*0.2inches /240*164*5mm	2	To fix the battery modules	

3 Installation

3.1 Device Installation

- 1) Take the device out of the box
- 2) Place the base on the ground, and then measure 65mm from the back of the base to the wall. Then use M8 screws to punch holes in the positions marked in the figure below and fix the base.

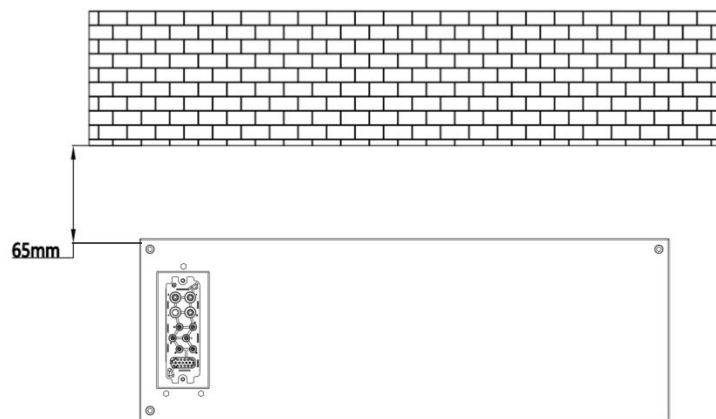

Figure 3.1.1. Mounting distance

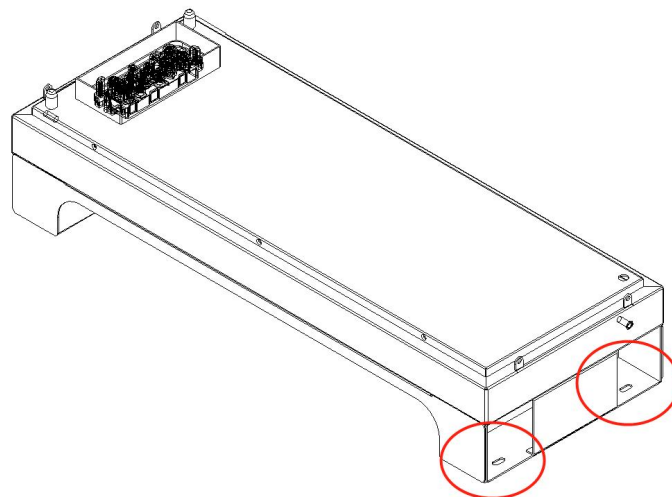

Figure 3.1.2. Mounting position

- 3) After securing the base, stack the remaining modules on top of each other. The main control unit must be placed in the uppermost layer. The sequence of the remaining modules is unaffected.

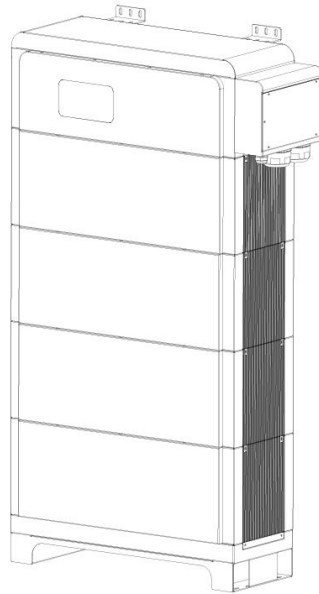

Figure 3.1.3. Battery

4) Use M4 screws to install the side panels of the modules as shown in the following figure. It should be noted that the base also has a base layer to install.

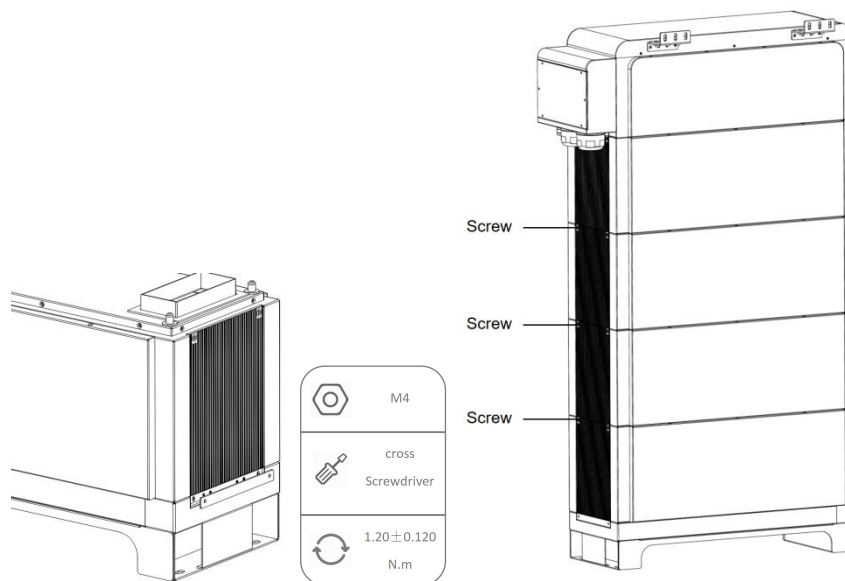

Figure 3.1.4. Base layer & Side panel

5) Install Mounting A and Mounting B on the back of the main control. Use M4 screws to secure Mounting A to the back of the main control, M6 screws to connect Mounting A to Mounting B.

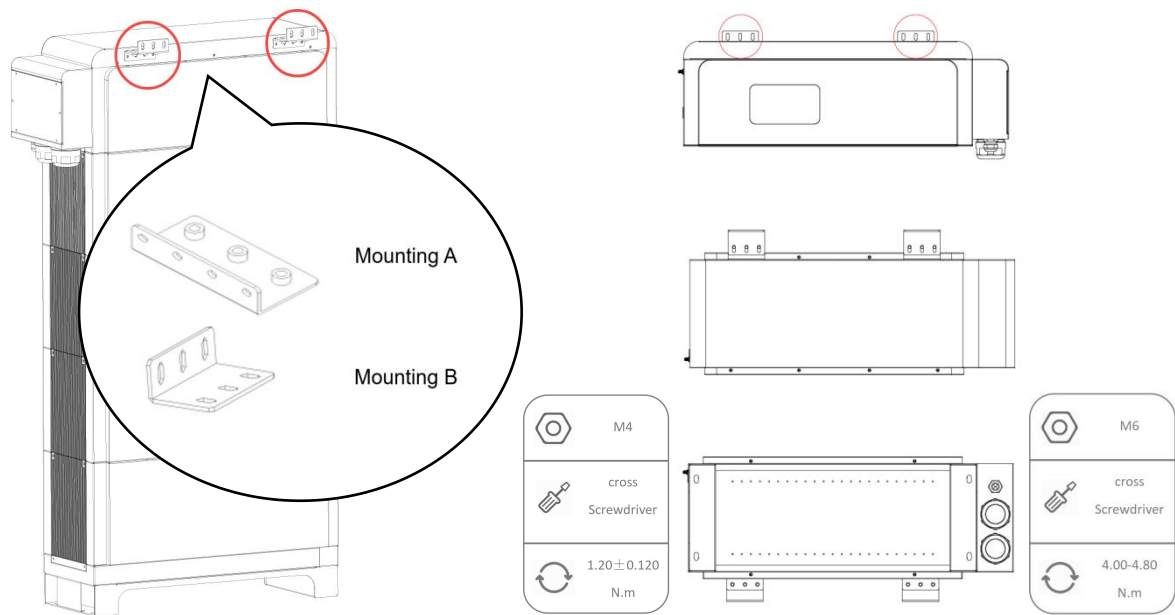

Figure 3.1.5. Mounting position & Master three views

6) Please first draw corresponding holes on the wall according to the position of the Mounting B behind the main control. Then drill holes and put them back on the main control, use M10 screws to fix to the wall. At last, install the remaining side panels that connect to the main control.

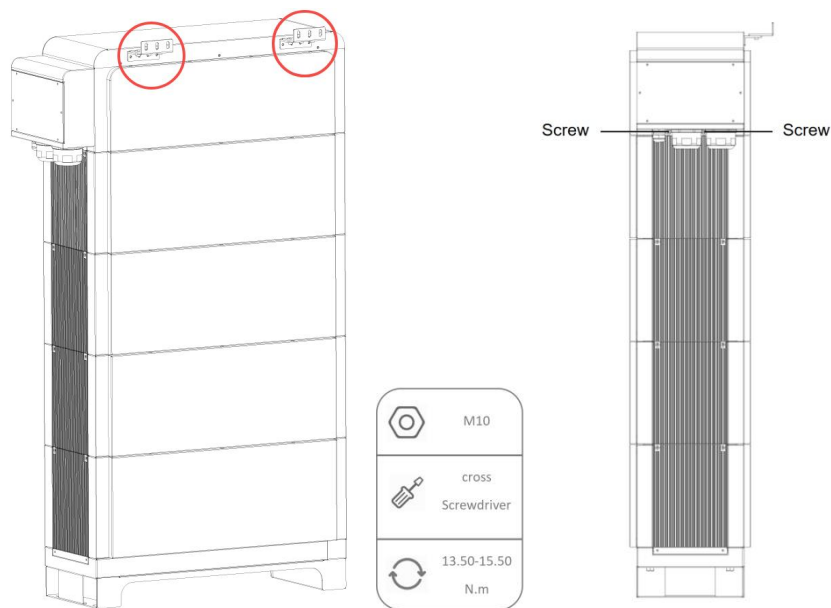

Figure 3.1.6. Mounting A position & Side panels connected to the main control

3.2 Connection

1) Remove the side cover panel of master to connect the cable.

This position is welded to the battery, only the side panel can be removed.

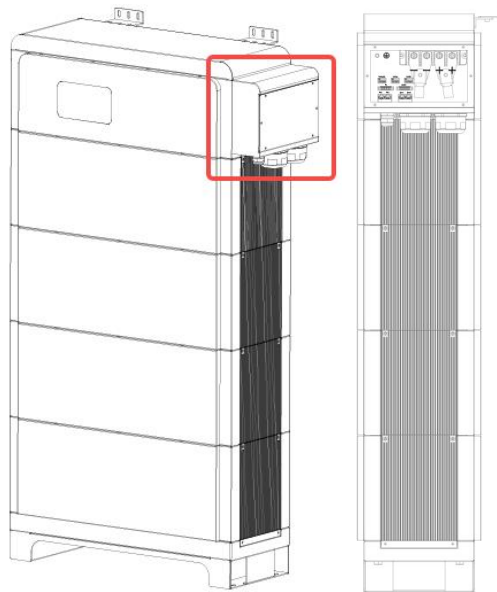

Figure 3.2.1. Side cover panel of master & Interface

2) Connect the ground wire as the diagram shows below.

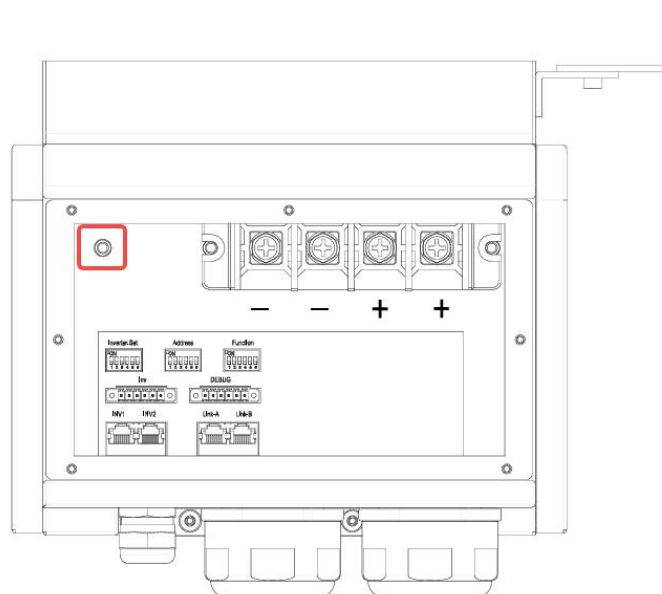

Figure 3.2.2. Grounding

3) Connect to inverter's negative and positive terminals.

Terminal type: 2/0 AWG

Torsion: 10N.m

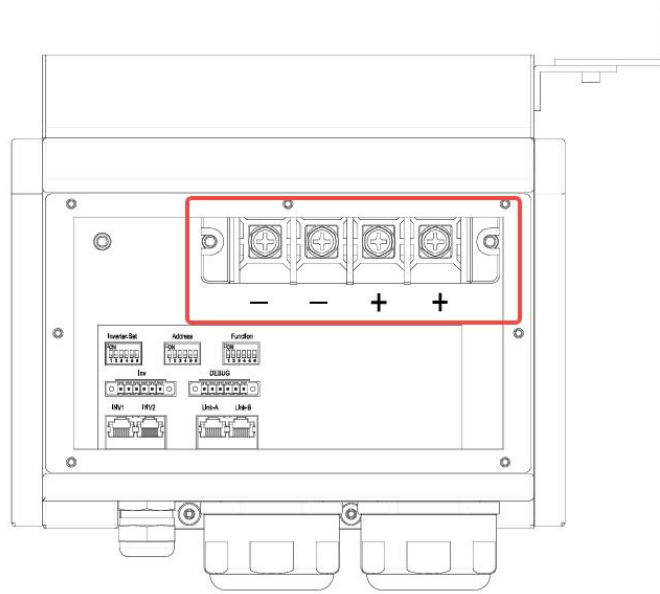

Figure 3.2.3. Positive & Negative

4) Communication cable connection

Pay attention to the marked communication knockouts, you need to remove the knockouts first before install. The knockouts consists of three parts, respectively block shot, knockouts rubber pad and plastic parts.

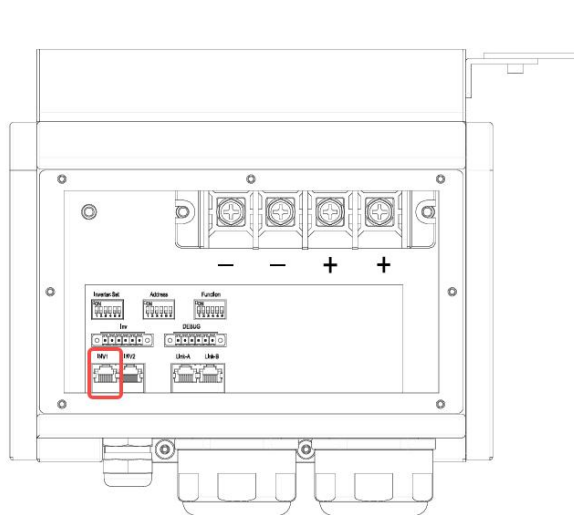

Figure 3.2.4. INV1 port

Note: Registered jack cannot go through the knockouts directly, please follow the steps below to install.

Step 1: Remove the block shot and fetch out the knockouts and rubber gasket.

Step 2: Gash the knockouts rubber pad follow the diagram to install communication cable.

Step 3: Install back to the original state in the order shown below after the communication cable goes through the knockouts.

Step 4: Simply tighten and install the three parts that have been sorted through the knockouts.

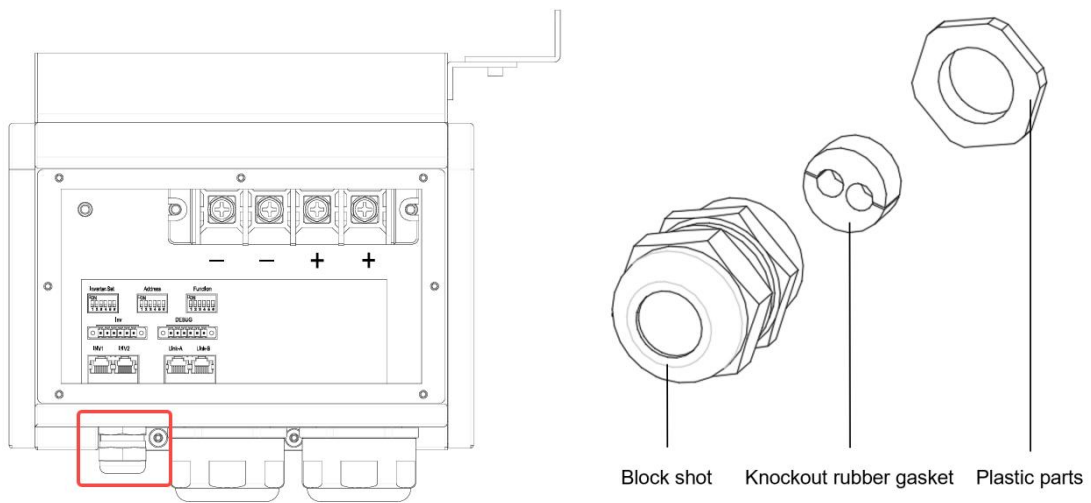

Figure 3.2.5. Communication cable connection & Knockouts parts

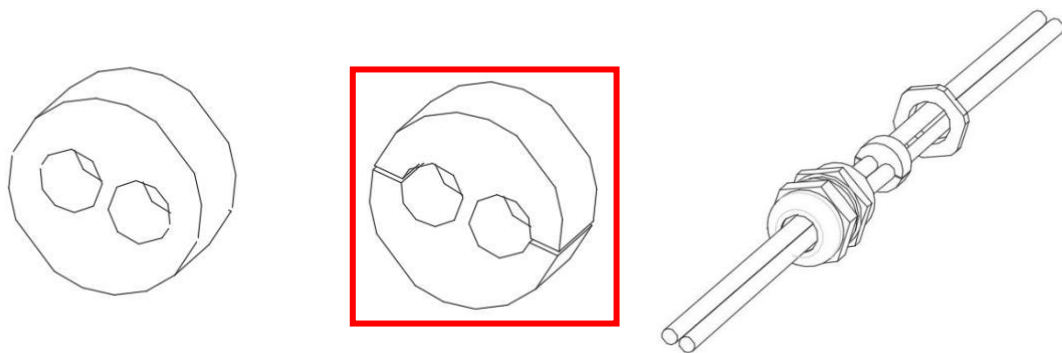

Figure 3.2.6. Knockout rubber gasket & Knockouts installation diagram

5) Dial code setting

Step 1: Please refer to the 5.3.3 Inverter Dial Switch for inverter configuration.

Step 2: Please refer to the 5.3.4 Address Dial Switch for address configuration.

Step 3: Please refer to the 5.3.5 Function Dial Switch for function configuration.

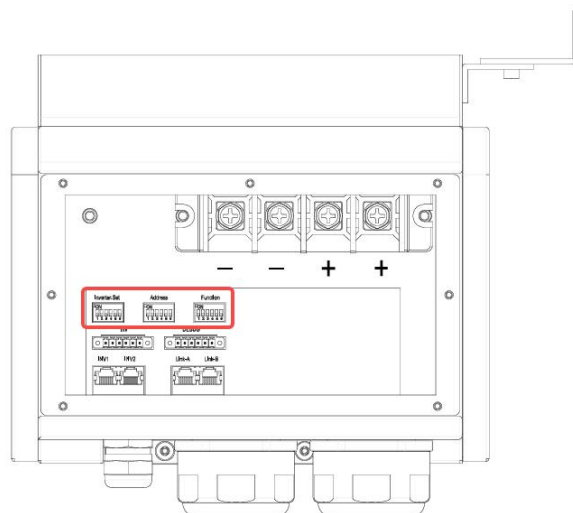

Figure 3.2.7. Dial code

3.3 Application scenarios



3.3.1 Single Stack

Step 1: Change the dial code of Inverter.Set, Address, and Function.

Step 2: Connect battery INV1 to inverter CAN Bus port.

Step 3: Connect the positive and negative terminal of the master to the positive and negative terminal of the slave using a 2*2/0 AWG DC cable, and then connect the two cables together to the positive and negative terminal of the battery port.

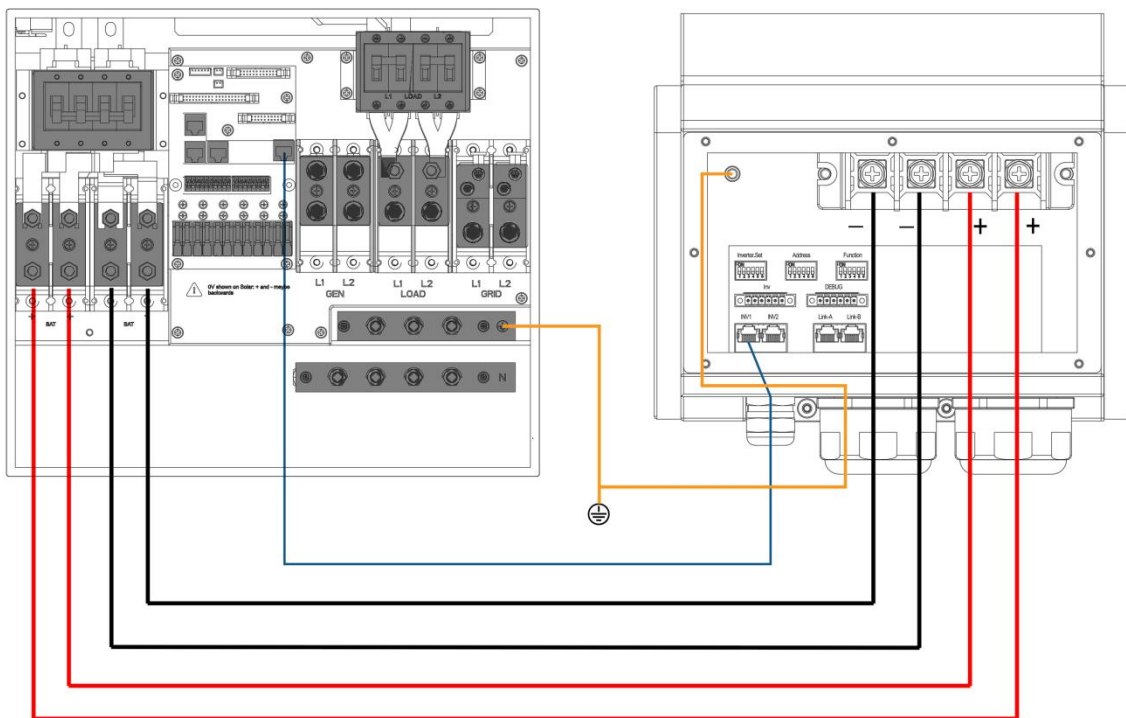

Figure 3.3.1. Connect with inverter

Exampel: Connect with Sol-Ark inverter.

	Address	Inverter	Function
Battery			

3.3.2 Parallel

Step 1: Change the dial code of Inverter.Set, Address, and Function.

Step 2: Connect Link-B of the master battery to Link-A of the slave battery.

Step 3: Connect battery INV1 to inverter CAN Bus port.

Step 4: Connect the positive and negative terminal of the master to the positive and negative terminal of the slave using a 2*2/0 AWG DC cable, and then connect the two cables together with the positive and negative terminal of the battery port.

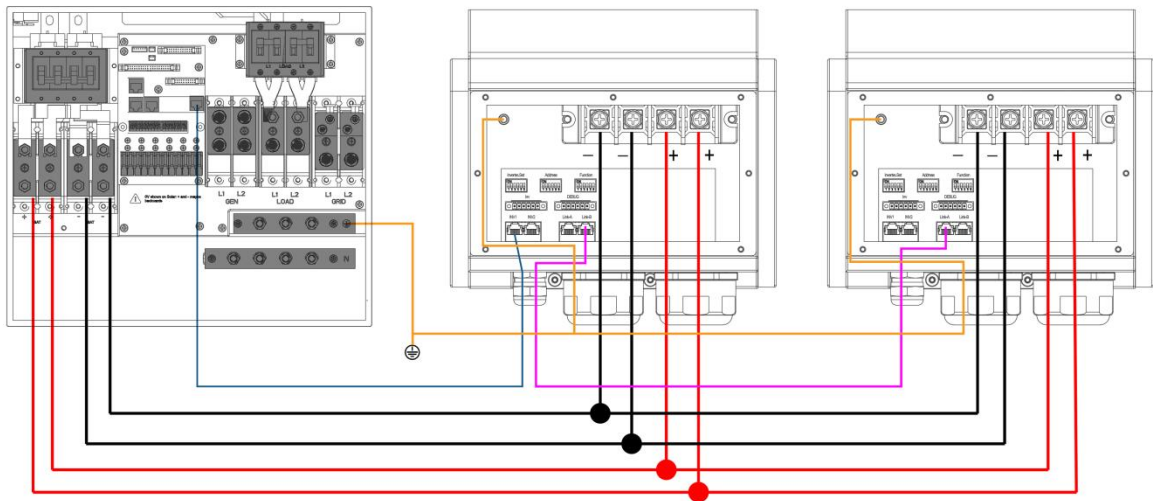

Figure 3.3.2. Diagram of two equipment in parallel

Example: Connect with Sol-Ark inverter.

	Address	Inverter	Function
Master			
Slave			

3.3.3 Precautions for Multiple Parallel Connections

1) Plan the distance between the two units and no less than 12 inches(300mm), and 20 inches (500mm) is recommended.

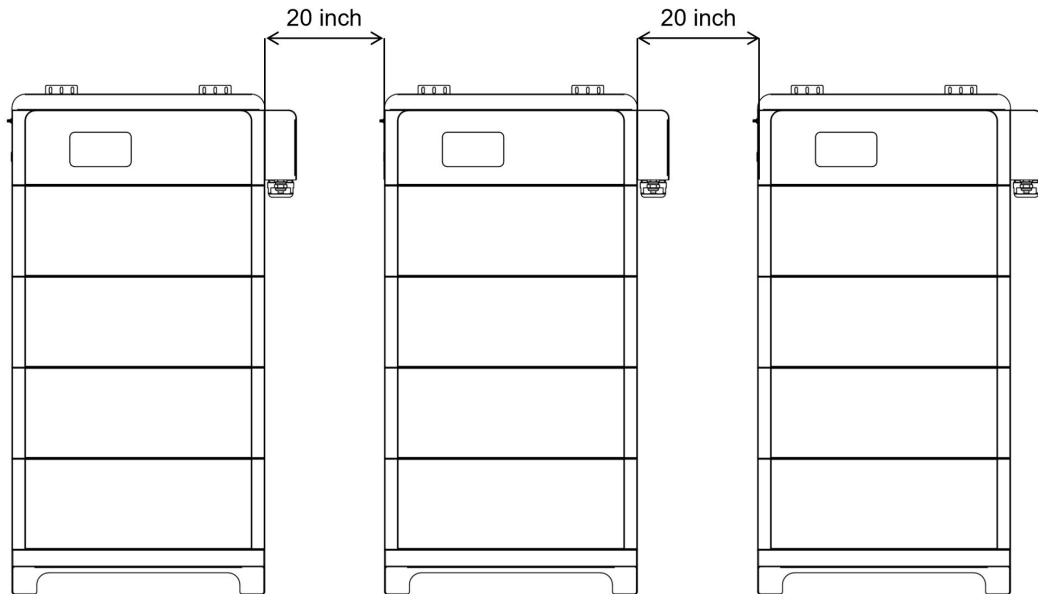

Figure 3.3.3. The distance between two adjacent battery stack

2) Before the parallel, every cluster's main controller needs to distinguish the number of battery modules for each cluster. Press the power button of each main controller. Listen for the beep sound which means the main controller has distinguished the number of battery modules are in the cluster successfully.

3) Turn off the system and then connect the positive and negative electrode of the cluster to busbar, the busbar must be able to withstand the maximum current of the system. Each main controller's address dial code should be set as 1,2, 3... in order.

4) Use parallel communication wire to connect with clusters. For instance, connect Link B of cluster 1 to Link A of cluster 2, and then connect Link B of cluster 2 to Link A of cluster 3, and so on.

Note: Multiple batteries in parallel require an additional busbar.

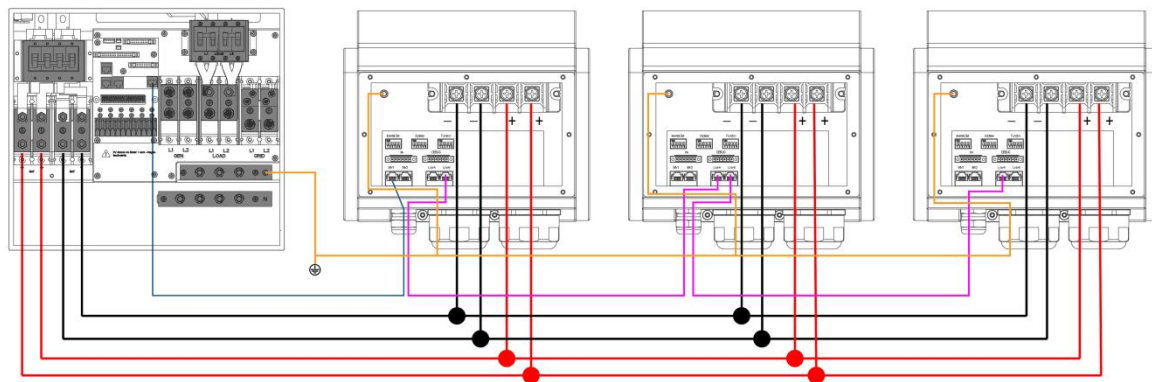

Figure 3.3.4. Diagram of multiple batteries in parallel

5) Set the first cluster and the last cluster of the system's function dial code as code 33 and set function dial code of remaining clusters to code 32.

Set the inverter dial switch according to the actual usage.

The address dial switch increases sequentially, please refer to the **6.3.4. Address Dial Switch** for details.

Example: Connect with Sol-Ark inverter.

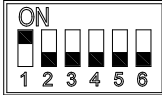
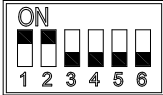
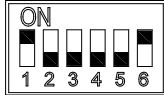
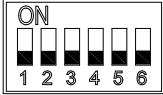
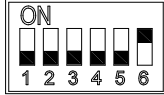
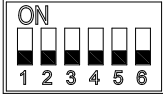
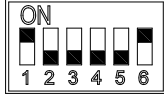
	Address	Inverter	Function
Master			
Slave n	...		
Slave n+1	...		

6) Make sure all clusters are turned on except first one. Turn on the first cluster to detect the number of clusters installed in parallel. After finishing this step, set the inverter dial code of the first cluster to the corresponding inverter's code. Only cluster 1 need to be connected to inverter by communication wire.

4 Cloud Platform Configuration

Screw the antenna into the antenna connection port firmly before WiFi configuration.

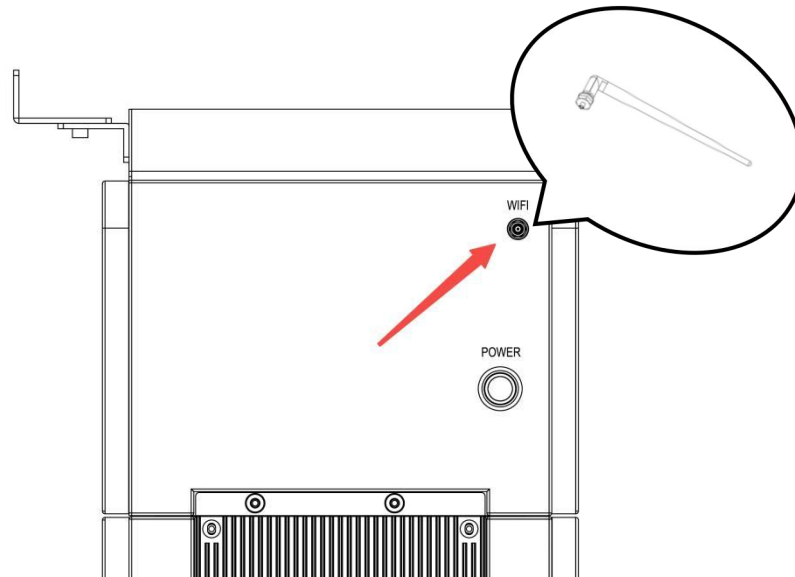
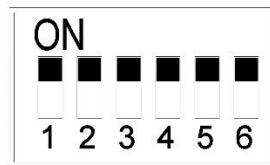

Figure 4.1.1. WiFi wiring position

Set the inverter dial code (**INV SET**) to 63(111111) as shown below before WiFi configuration.



1) Download App

Download and install Renon App from Google Play or Apple Store by searching “Renon Smart”.



Figure 4.1.2. Install Renon App



Figure 4.1.3. Android QR code



Figure 4.1.4. IOS QR code

2) Register

You may acquire the Registration Code from your installer for new account registration. If you already have an account, you may use it to login the app directly, otherwise you need to create an account.

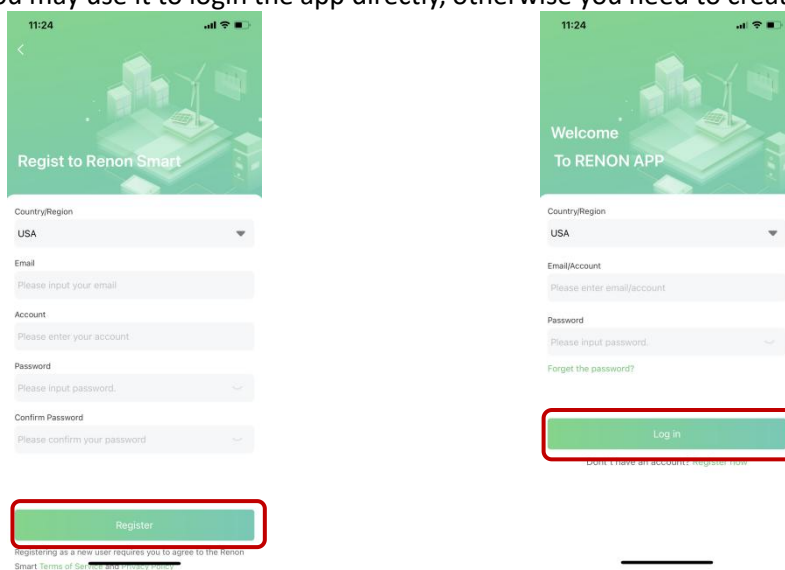

Figure 4.1.5. Register & Log in

3) Binding

After registering, unbound user as General User.

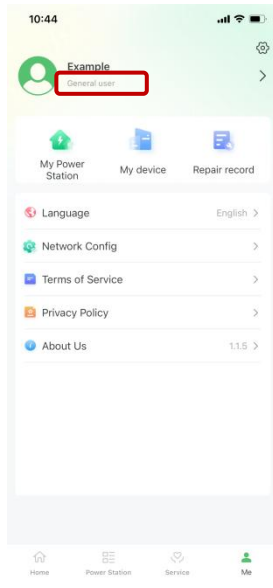

Figure 4.1.6. Binding

a. Distribution

Contact your upper-level installer to get a binding QR code, and scan the QR code to become an end user. After becoming an end user, ask the installer to assign the device to your end user account.

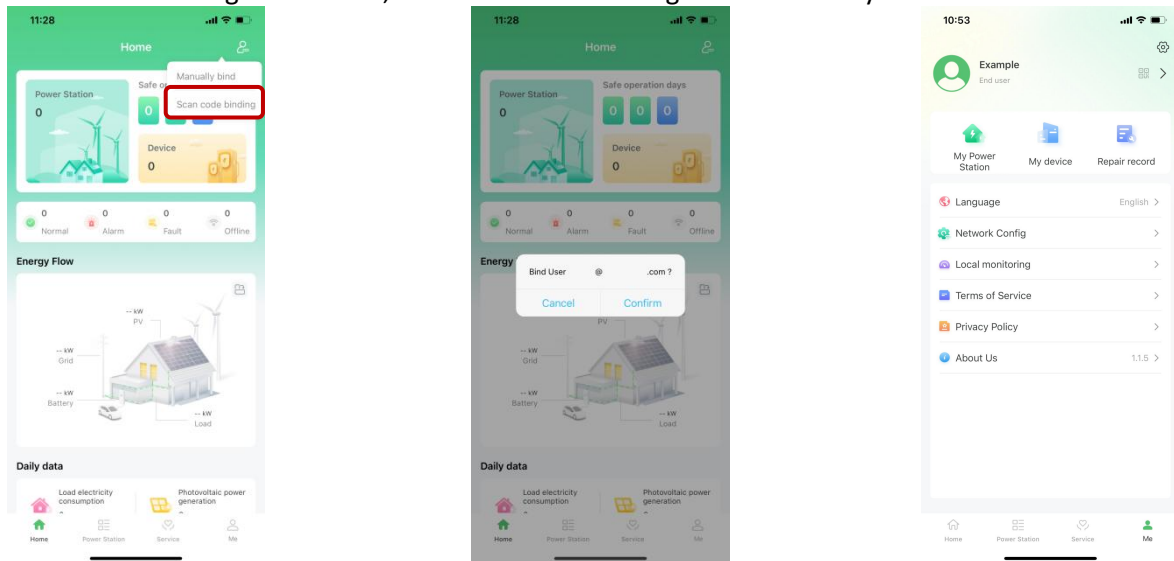

Figure 4.1.7. Scan upper-level account & Confirm binding & Become end user

b. Scan bar code

If you cannot contact the installer, please try to scan the device's bar code to bind the device.

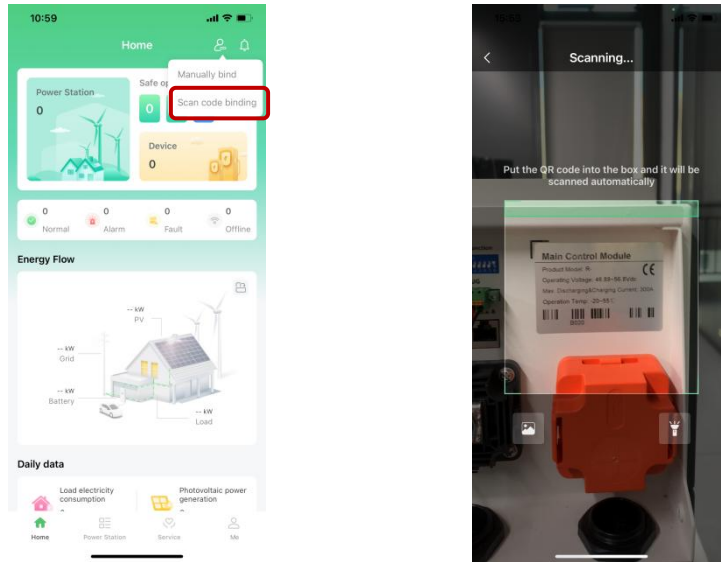

Figure 4.1.8. Scanning bar code

c. Contact Renon

If the above methods are not successful, please contact Renon for processing, email address: support@renon-usa.com, Renon Power Support: +1 (833) 736-6687. Be sure to write your account name/email address and device serial number clearly.

4) WiFi configuration

a. Bluetooth

Turn to the page Me, click the Network configuration, then click Bluetooth Model, and following by the instruction of network setting for WiFi configuration.

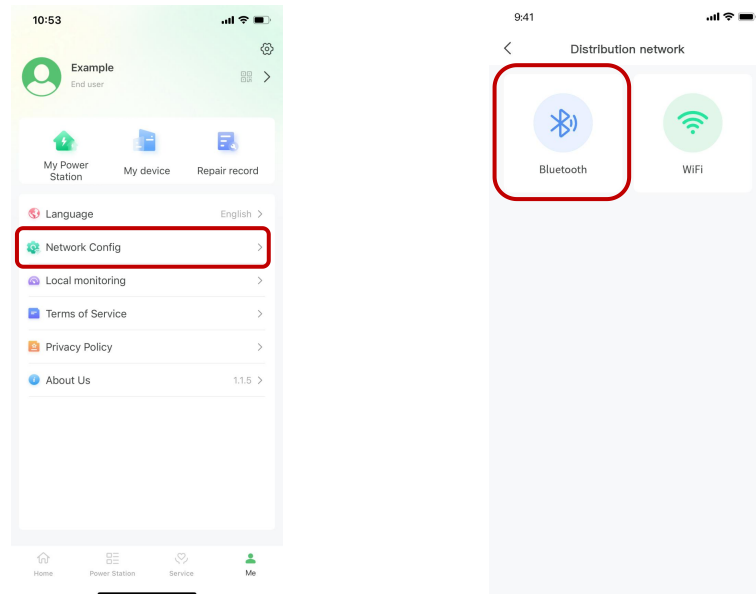

Figure 4.1.9. Bluetooth network setting

Connect your mobile phone to the Bluetooth and wait. If the device is found, click it and turn to the Bluetooth network configuration page.

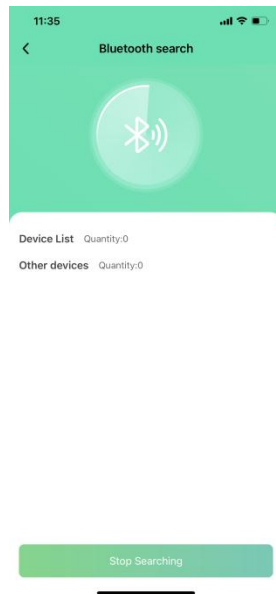

Figure 4.1.10. Connect battery Bluetooth

Enter the WiFi name and password of your private WiFi for connecting master controller.

Note: Device that has been assigned to the end user will automatically fill in the key.

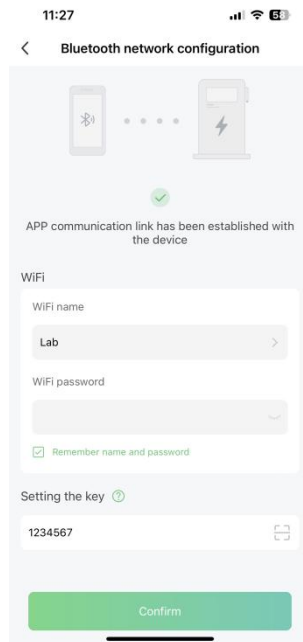

Figure 4.1.11. Connecting private WiFi

b. WiFi

If you cannot find the Bluetooth from the battery. Please go back to Distribution network interface, and click WiFi model, by the of network settings for WiFi configuration.

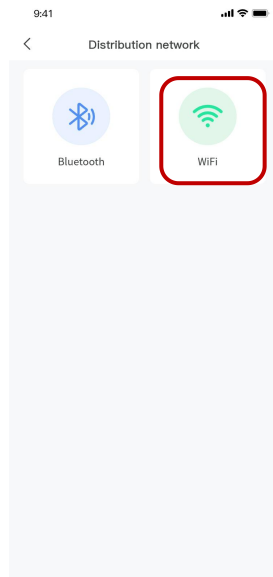

Figure 4.1.12. WiFi network settings

Fill in the serial number of the device you want to configure and enter the device Verification code.

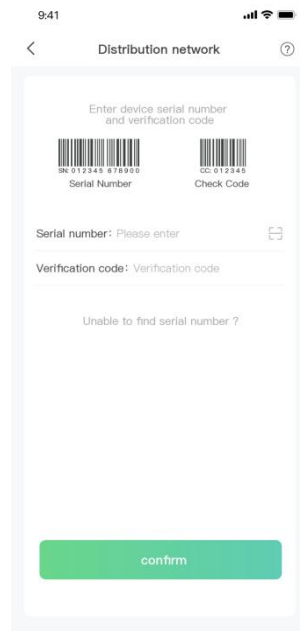

Figure 4.1.13. Enter Device serial number and verification code

5) Create a power station

Navigate to the Power Station page on the app, Create a power station. Set a station name. Select a power station type. Enter price configuration, superiors view, power station address, and upload pictures of your power station.

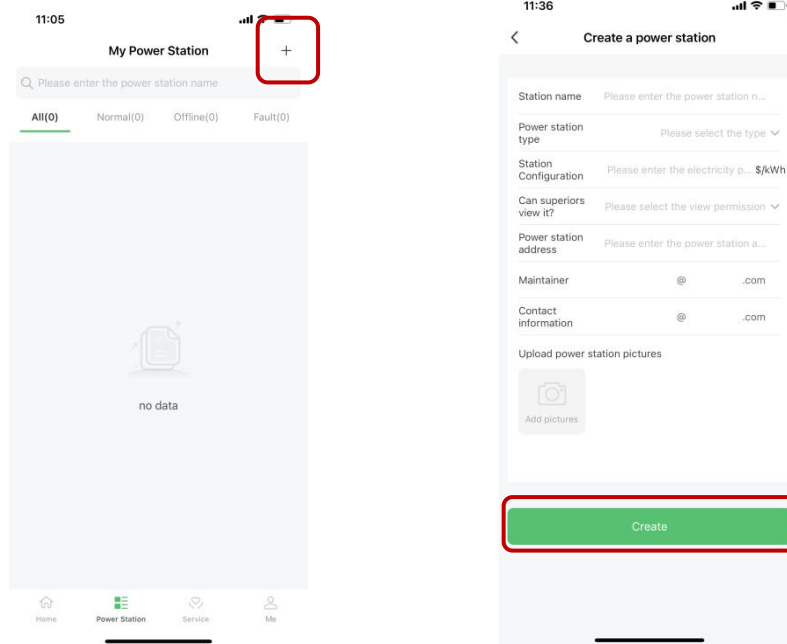

Figure 4.1.14. Create a new power station

The power station will appear after creating a power station successfully. Select the power station and turn to the page for detail. Select the Add a device. On the Binding Device page, select the device that you want.

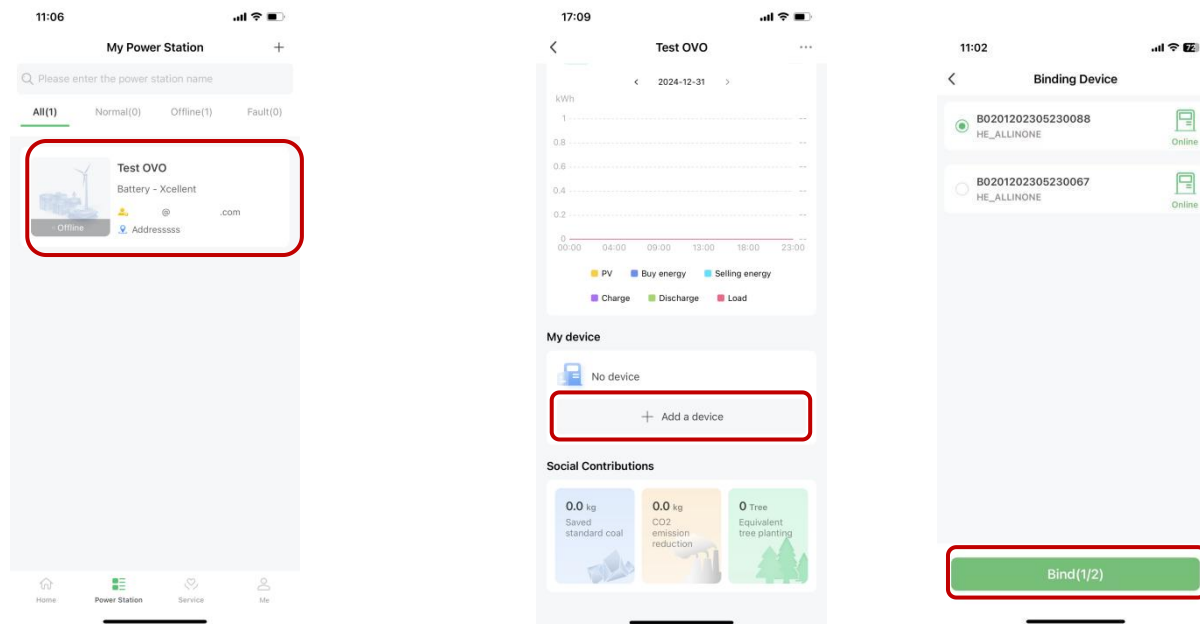

Figure 4.1.15. Manage your power station& Confirm your device

Now you can manage your device in the app, and you can also manage it on the website. Ask your installer for the site URL.

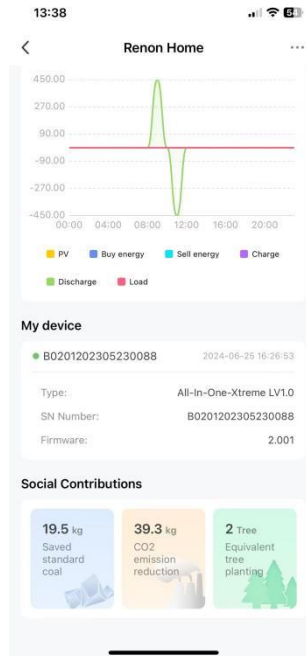

Figure 4.1.16. Manage your device

After the device is connected to WiFi, the running status, real-time power, daily power consumption and cumulative power of the product can be monitored in real time on the network platform or mobile app. It can also be used to configure parameters.

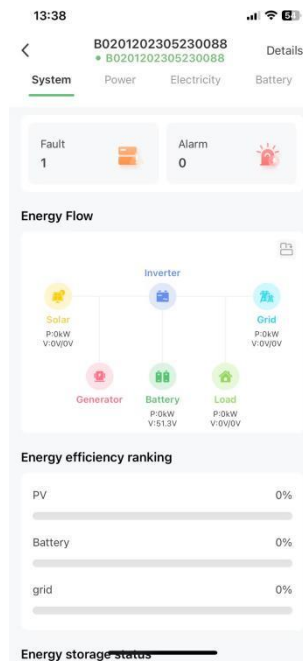

Figure 4.1.17. Monitoring device

Set the inverter dial code to match the inverter brand after WiFi configuration is complete (Please refer to the chapter **5.3.3 Inverter Dial Switch**).

5 Battery Specifications

The Xtreme LV series is a lithium iron phosphate (LFP) battery-based energy storage product developed and produced by RENON, it can supply reliable power for nearly all kinds of household appliances and equipment.

The Xtreme LV series consists of a main controller and several battery modules, each battery module has a built-in BMS battery management system, which can manage and monitor cells information including voltage, and a DC-DC converter, current and temperature, used to limit the balance current between different batteries when parallel use.

Multiple battery stacks are allowed to be connected to expand capacity and power to meet the requirements of longer power supporting duration and higher power consumption.

5.1 Product Features

- With a DC-DC converter inside, users can extend or change battery modules whenever they want, no need to consider the quality or SOC of old modules.
- The whole product is non-toxic, pollution-free, and environment-friendly.
- The battery chemistry is made from LiFePO₄ with safety, performance, and a long cycle life.
- The battery is small in volume, has plug & play embedded design module, and is easy to install and maintain.
- Working temperature range is between -4°F and 122°F (-20°C to 50°C) with excellent discharge performance.
- The battery management system (BMS) has protection functions for over-discharge, over-charge, over-current, and high/low temperature.
- The battery can self-discharge up to 3 months without charging. It has no battery memory effect, and offers excellent performance of shallow charge and discharge.
- The system can automatically manage battery charge and discharge state, and save energy cost with various automatic options.

5.2 Specifications

5.2.1 Specifications 1 (16 series cells)

Item	R-XL010021 (-H)	R-XL015031 (-H)	R-XL020041 (-H)	R-XL025051 (-H)	R-XL030061 (-H)	R-XL035071 (-H)	R-XL040081 (-H)
Controller Model	R-MC300-XTL01						
Battery Module Model	R-EM51100-XTL01 (-H)						
Battery Chemistry	LiFePO4						
Module Quantity	2	3	4	5	6	7	8
Nominal Energy (kWh)	10.24	15.36	20.48	25.60	30.72	35.85	40.96
Nominal Capacity (Ah)	200	300	400	500	600	700	800
Max. Charging/Discharging Current (A)	190	285	300	300	300	300	300
Nominal Voltage (V)	51.2						
Recommend Charging Voltage (V)	56.8						
Max. Charging Voltage (V)	58.4						
Discharge Cut-off Voltage (V)	43.2						
Heating Film Resistance(Ω)	16 per module (-H model only)						
Heating Start Temperature (°F/°C)	41/5 (-H model only)						
Operation Temperature(°F/°C)	Discharge: -4~122 / -20~50 Charge: 32~122 / 0~50						
Safety Function	Over-charge, Over-discharge, Over-current, Low/High-temperature, Short-circuit Protections						
Parallel Capacity	Maximum 15 Clusters						
Communication	RS485/CAN/Wi-Fi						
Weight (lbs/kg)(Approx.)	311/141	428/194	545/247	661/300	778/353	895/406	1012/459
Physical Dimensions (inches/mm)(W*D*H)	25.0*10.6*31.3/635*268*795	25.0*10.6*40.3/635*268*1023	25.0*10.6*49.2/635*268*1250	25.0*10.6*58.2/635*268*1478	25.0*10.6*67.1/635*268*1705	25.0*10.6*76/635*268*1932	25.0*10.6*84.9/635*268*2159
Level of Protection	IP65						
Altitude	≤4000m						

5.2.2 Specifications 1 (15 series cells)

Item	R-XL009021 (-H)	R-XL014031 (-H)	R-XL019041 (-H)	R-XL024051 (-H)	R-XL028061 (-H)	R-XL037071 (-H)	R-XL046081 (-H)
Controller Model	R-MC300-XTL01						
Battery Module Model	R-EM48100-XTL01 (-H)						
Battery Chemistry	LiFePO4						
Module Quantity	2	3	4	5	6	7	8
Nominal Energy (kWh)	9.6	14.4	19.2	24	28.8	33.6	38.4
Nominal Capacity (Ah)	200	300	400	500	600	700	800
Max. Charging/Discharging Current (A)	190	285	300	300	300	300	300
Nominal Voltage (V)	48						
Recommend Charging Voltage (V)	53.25						
Max. Charging Voltage (V)	54.75						
Discharge Cut-off Voltage (V)	40.5						
Heating Film Resistance(Ω)	16 per module (-H model only)						
Heating Start Temperature (°F/°C)	41/5 (-H model only)						
Operation Temperature(°F/°C)	Discharge: -4~122 / -20~50 Charge: 32~122 / 0~50						
Safety Function	Over-charge, Over-discharge, Over-current, Low/High-temperature, Short-circuit Protections						
Parallel Capacity	Maximum 15 Clusters						
Communication	RS485/CAN/Wi-Fi						
Weight (lbs/kg)(Approx.)	308/139.5	424/192.5	541/245.5	658/298.5	775/351.5	894/404.5	1009/457.5
Physical Dimensions (inches/mm)(W*D*H)	25.0*10.6*31.3/635*268*795	25.0*10.6*40.3/635*268*1023	25.0*10.6*49.2/635*268*1250	25.0*10.6*58.2/635*268*1478	25.0*10.6*67.1/635*268*1705	25.0*10.6*76/635*268*1932	25.0*10.6*84.9/635*268*2159
Level of Protection	IP65						
Altitude	≤4000m						

Note: -H indicates that this product contains a heating film and has a heating film function.

5.3 Interface Information

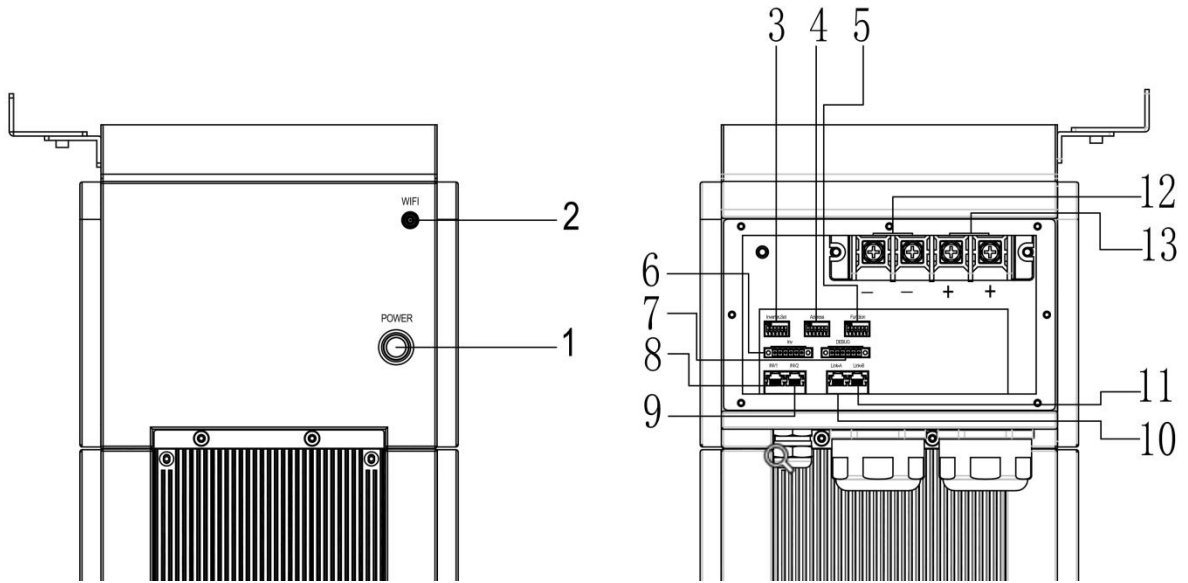

Figure 5.3.1. Interface definition of controller module

No.	Instructions	No.	Instructions
1	Power Button	8	Inverter 1 Communication Port (RJ45)
2	WiFi Antenna Port	9	Inverter 2 Communication Port (RJ45)
3	Inverter Dial Switch	10	Parallel Communication Port A
4	Address Dial Switch	11	Parallel Communication Port B
5	Function Dial Switch	12	Power Negative
6	Inverter Communication Port (connector)	13	Power Positive
7	Debug		

5.3.1 Power Button

Press this button once to power on the system, and press it again to power off.





5.3.2 WiFi Antenna Port7

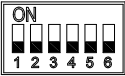

Connect the WiFi antenna to the port in order to get the APP and WEB connection.

5.3.3 Inverter Dial Switch

Code 0~26 of this Dial Switch are used to match which brand of inverter is using.











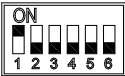



The definitions of code 0 ~ 26 are shown as below table.

Code	Dial Switch Position	Brand	Logo
0		APP setting (Default: Renon Flex)	
1		Reserved	Reserved
2		Schneider Gateway	
3		Sol-Ark	
4		Solis	
6		Studer Xtender	
7		Victron	
8		SMA	
9		Sermatec	
10		Sofar	
11		DEYE	
12		Growatt SPF	

13		Growatt SPH	
14		Must	
15		MEGAREVO	
16		SAJ	
17		Aiswei	
18		Phocos	
22		Voltronic Power	
23		Fronius	
24		Afore	
25		Lux Power	
26		CHISAGE ESS	

5.3.4 Address Dial Switch



- 1) Use this Dial Switch to set the address of each master controller, and then turn on to activate the system when it needs to be in parallel with other stacked units.
- 2) When the system only has one stack, dial the address to Cluster 1.
- 3) When the system is used in parallel mode, set the address start from 1, and increase by the number of stacked units in order to communicate with other stacks.
- 4) The illustration of dialing shown below:

Code	Dial Switch Position	Definition
1		Set as Cluster 1 (communicate with inverter by this cluster)
2		Set as Cluster 2
3		Set as Cluster 3
4		Set as Cluster 4
5		Set as Cluster 5
6		Set as Cluster 6
7		Set as Cluster 7
8		Set as Cluster 8
9		Set as Cluster 9
10		Set as Cluster 10
11		Set as Cluster 11
12		Set as Cluster 12
13		Set as Cluster 13
14		Set as Cluster 14
15		Set as Cluster 15

5.3.5 Function Dial Switch

Use this dial switch to match the communication impedance:

Optimize and enhance the communication between the master control unit and the battery so as to communicate between paralleled clusters.

Code	Dial Code Switch Position	Definition
32		<ul style="list-style-type: none"> ① When used as single cluster; ② When used in a parallel system and not being the first or last cluster.
33		<ul style="list-style-type: none"> ① When used as the first or last cluster in a parallel system.

5.3.6 Inverter Communication Port

Terminal type: 6-Pin terminal block

Usage: reserved for direct connection with inverter, same function as the RJ45 port (chapter " **INVERTER 1 Port (RJ45)**"), either one of these two can be used.

Defined as below:

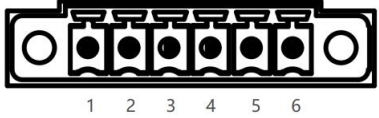
6pin Terminal	Pin	Usage
	1	RS485_2A
	2	RS485_2B
	3	RS485_2GND
	4	CAN2GND
	5	CAN2L
	6	CAN2H

5.3.7 Debug Port

Terminal type: 6-Pin terminal block

Usage: reserved for our technical to debug.

Defined as below:

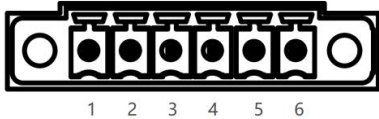
6pin Terminal	Pin	Usage
	1	DIN+
	2	DIN-
	3	BAT_SW_IN
	4	BAT_SW_OUT
	5	CAN1H
	6	CAN1L

5.3.8 INVERTER 1 Port (RJ45)

Terminal type: RJ45

Usage: Communicates with inverter, PCS, or other equipment.

Installer needs to check the cable pin out before connecting inverter to the battery in order to ensure communication.

Illustration of battery connection port shown below:

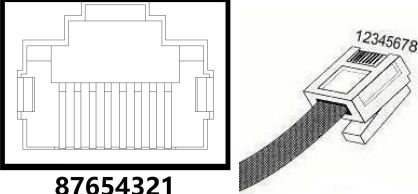
Port	RJ45 Pin	Function
	1	RS485_2B
	2	RS485_2A
	3	SGND
	4	SGND
	5	SGND
	6	SGND
	7	CAN2H
	8	CAN2L

5.3.9 INVERTER 2 Port (RJ45)

Terminal type: RJ45

Usage: Communication with inverter internet port in order to upload inverter data to our platform.

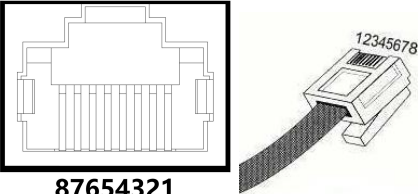
Port	RJ45 Pin	Function
	1	RS485_2B
	2	RS485_2A
	3	SGND
	4	RS232RIN1
	5	RS232OUT1
	6	SGND
	7	RS485_2B
	8	RS485_2A

5.3.10 Parallel Communication Port A & B

Terminal type: RJ45 *2

Usage: Link A & Link B are parallel communication ports with the same definition. When more than one cluster is connected in parallel, use these ports to connect the clusters one by one.

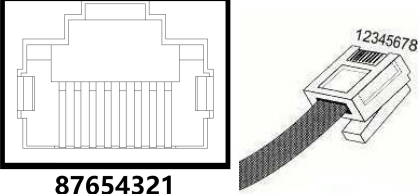
Port	RJ45 Pin	Function
	1	CAN2L
	2	CAN2H
	3	CAN2GND
	4	CAN2GND
	5	CAN2GND
	6	CAN2GND
	7	CAN2H
	8	CAN2L

5.3.11 Power Negative & Positive

Power terminal information for details shown below:

OT terminal	Screw	Torsion	Wire diameter
SC120-8	M8	10N.m	4/0 AWG
SC70-8	M8	10N.m	2/0 AWG

5.3.12 Dial Code Switch

- 1) Set the Address dial code as 1 and set the function dial code as 32 in binary formation.

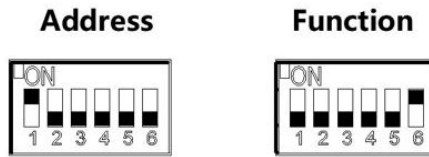

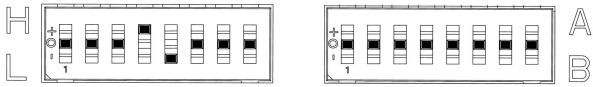
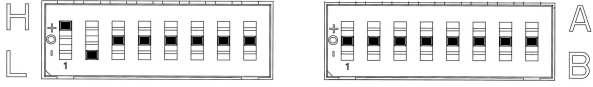









Figure 5.3.2. Dial code

2) Remove the cover of the positive and the negative electrodes. Connect the battery positive and negative electrodes with the inverter's positive and negative electrodes separately.

3) Connect CAN/RS485 wire to the inverter port of the master controller and inverter's CAN/RS485 port.

If you are using the pin order select box, please refer to the table below to set the dial switch according to the inverter brand. If the inverter brand is not shown in the table, please refer to the inverter manual or consult Renon's engineer.

Dial Switch Position		Inverter	Comm Mode
 CAN	 RS485	Schneider_Gateway	CAN
 CAN	 RS485	Sol-Ark	CAN
 CAN	 RS485	Solis	CAN
 CAN	 RS485	Studer	CAN
 CAN	 RS485	Victron	CAN
 CAN	 RS485	SMA	CAN

 <p>CAN RS485</p>	Sermatec	CAN
 <p>CAN RS485</p>	Sofar	CAN
 <p>CAN RS485</p>	DEYE	CAN
 <p>CAN RS485</p>	Growatt_SPF	RS485
 <p>CAN RS485</p>	Growatt_SPH	CAN
 <p>CAN RS485</p>	Must	CAN
 <p>CAN RS485</p>	MEGAREVO	CAN
 <p>CAN RS485</p>	SAJ	CAN
 <p>CAN RS485</p>	Aiswei	CAN
 <p>CAN RS485</p>	Phocos	RS485
 <p>CAN RS485</p>	Voltronic Power	RS485

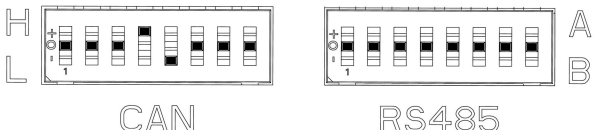
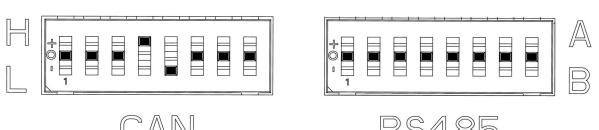
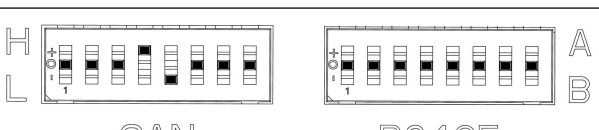
 <p>CAN RS485</p>	Afore	CAN
 <p>CAN RS485</p>	Lux Power	CAN
 <p>CAN RS485</p>	CHISAGE ESS	CAN

5.4 LCD Screen

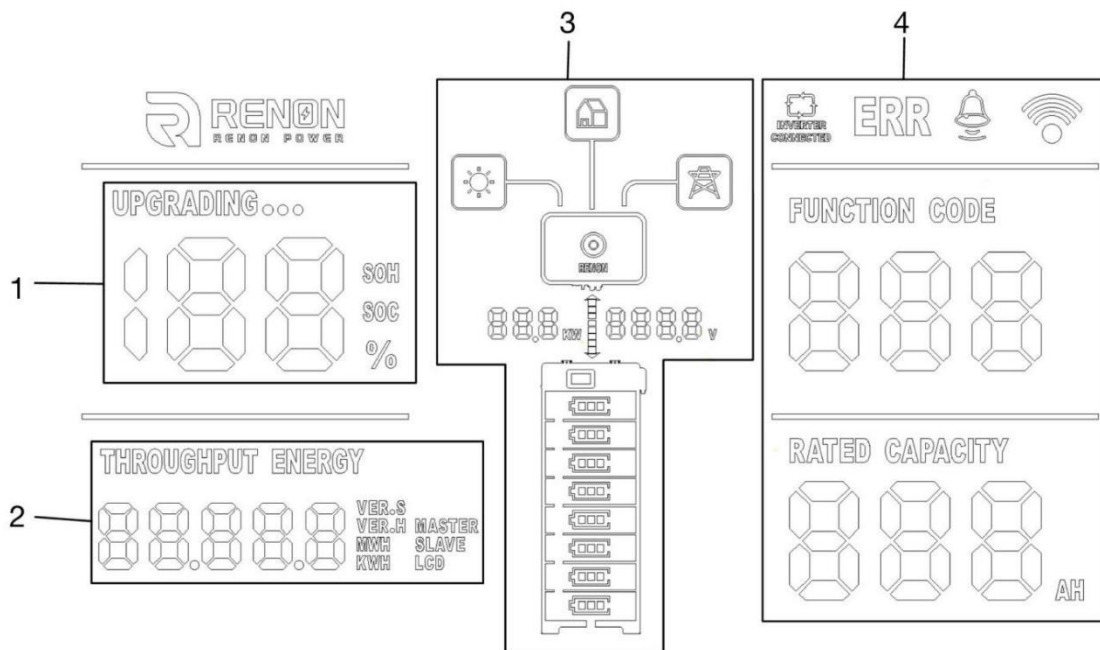

Figure 5.4.1 LCD Screen introduction

No.	Instructions
1	SOC, SOH and Upgrading State
2	Version and Accumulated Discharge Energy
3	ESS status, Power, and Voltage
4	Battery Operation State

5.4.1 SOC, SOH and Upgrading State

1) The SOC percentage displays when the SOC symbol displays a light underneath, and the current SOH when there is a blinking light underneath SOH. The SOC lights up in 60 second intervals, and the SOH lights up in 3 second intervals.

2) The “UPGRADING...” icon will show up when the battery is performing an upgrade. The percentage indicates the progress of the upgrade.

5.4.2 Version and Accumulated Discharge Energy

The number show the version of software and hardware for LCD, master, slave, and accumulated discharged energy in kWh or MWh, respectively. Each item will be displayed in 3 second intervals.

5.4.3 ESS Status, Power, and Voltage

1) This number displays current power and voltage of the complete battery stack. Direction of the arrow between those two numbers indicates if it's charging or discharging.

2) The battery module icons will indicate the number of battery modules. Online modules will have lights on constantly while offline modules will blink periodically.

5.4.4 Battery Operation Status

1) Indication Code

If there is any error or warning sign, the Indication Code will show up. When the Indication Code displays “ERR”, it means there an error has occurred. The Indication Code displays “🔔” as a warning reminder. When there is no warning or error, the function code will show as 0.

2) Inverter Connection

“INVERTER CONNECTION” indicates the status of the connection between inverter and battery. It will display when proper connection is detected. Otherwise, it will be off.

3) WiFi Connection Symbol

The WiFi icon will display as long as the WiFi connection is sufficient. It will blink periodically when the WiFi configured for the battery cannot connect to the server. Off means the battery is waiting for WiFi configuration.

No.	Status	Instructions
1	Cloud platform connection	Light on
2	WiFi connection	Flashing
3	Not connection	Light off

4) Rated Capacity

Rated Capacity indicates the nominal capacity of current cluster.

5.4.5 Screen Display Code

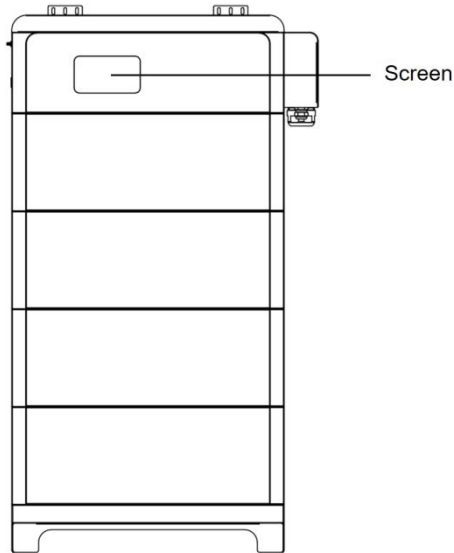

Figure 5.4.2 Screen

Note: If the following fault codes are not displayed on the screen, the will operate as intended.

Warning Code (Sign like "🔔")

No.	Code	Warning Type
1	1	Battery cell undervoltage protection
2	2	Overcurrent charge protection
3	3	Overcurrent discharge protection
4	4	High charge temp protection

5	5	High discharge temp protection
6	6	Low charge temp protection
7	7	Low discharge temp protection
8	8	High ambient temp protection
9	9	Excessive voltage difference protection
10	10	Excessive temp of main control relay
11	11	Overtemp protection of master DC busbar
12	12	Low insulation resistance protection
13	13	Low total voltage protection
14	14	Low ambient temp protection
15	15	High MOS temp protection
16	16	Battery cell overvoltage protection
17	17	High total voltage protection
18	18	Low SOC protection
19	19	Overcurrent discharge 2 protection
20	22	Positive connector high temp protection
21	23	Negative connector high temp protection
22	24	Relay high temp protection
23	25	Positive high temp protection for docking terminal
24	26	Negative high temp protection for docking terminal
25	27	Positive high temp protection for discharge port
26	28	Negative high temp protection for discharge port
27	30	Charger overvoltage protection
28	400	PCS disconnect(All-in-one only)

Error Code (Display as "ERR")

No.	Code	Error Type
1	100	The main control discharge relay is faulty
2	101	The main control charge relay is faulty
3	102	Battery cell fault
4	103	NTC fault
5	104	Current sensor fault
6	105	Pack disconnection
7	106	Short circuit fault
8	107	Internal total voltage detection fault
9	108	Heating fault
10	109	Battery module conflict
11	110	Cluster address conflict
12	111	Charge MOS fault
13	112	Discharge MOS fault
14	113	Addressing failure
15	114	Precharge fault
16	115	Cluster disconnection
17	116	Battery reverse connection fault
18	117	External total voltage detection fault
19	118	Address non-1 fault
20	119	Address break-sign failure
21	123	Microelectronic fault
22	124	Smoke sensor fault
23	125	The number of slave voltage strings does not match
24	126	Temp NTC short circuit of master relay
25	127	Temp NTC open circuit of master relay
26	128	Temp NTC short circuit of master DC busbar



27	129	Temp NTC open circuit of master DC busbar
28	130	Master drop-off fault
29	132	EMS SN is empty
30	133	Master SN is empty
31	134	Pack SN is empty
32	136	Relay voltage fault
33	200	Battery cell undervoltage safety lock
34	201	Battery cell high voltage safety lock
35	202	Charge high temp safety lock
36	203	Charge low temp safety lock
37	204	Discharge high temp safety lock
38	205	Discharge low temp safety lock
39	206	Charge overcurrent safety lock
40	207	Discharge overcurrent safety lock

6 Troubleshooting & Maintenance

6.1 Regular Maintenance

- 1) Check the battery modules every 3 months to verify whether there are damages.
- 2) Check the battery modules every 3 months to verify that the operating parameters are normal and there is no abnormal heating.
- 3) Fully charge and discharge the battery system every 3 months.
- 4) Clean the battery modules with a dry rag once a month.

6.2 Troubleshooting

Phenomenon	Investigation & troubleshooting
<p>The number of battery module symbol is incorrect.</p> 	<ol style="list-style-type: none"> 1. Make sure the whole battery system is stacked neatly; 2. Try to restart the battery system.
<p>The symbol of battery modules on the screen is blinking (frequency of 1s)</p> 	<ol style="list-style-type: none"> 1. Make sure the whole battery system is stacked neatly; 2. Make sure the function dial switch code setting is correct, please refer to chapter "function dial switch"; 3. Try to restart the battery system.
<p>The symbol of battery modules on the screen is rapid blinking (frequency of 2s)</p> 	<ol style="list-style-type: none"> 1. Try to charge and discharge the battery system for a cycle.
<p>Unable to turn on the battery</p>	<ol style="list-style-type: none"> 1. Try to charge the battery with the activation charging function on the inverter when power is on.

<p>Unable to find the battery on the app or the Cloud</p>	<ol style="list-style-type: none"> 1. Make sure the WiFi antenna is tightened screwed properly; 2. Make sure the WiFi configuration is correct; 3. Make sure the SSID & PASSWORD of your private WiFi is correct, please enter information case-sensitively without space; 4. Make sure the WiFi signal is strong enough; 5. Make sure WiFi is working; 6. Make sure installer has added your products to your account; 7. Try to restart the router.
<p>No output after power on.</p>	<ol style="list-style-type: none"> 1. Make sure the address dial code setting is correct, refer to the chapter of address dial code; 2. Make sure SOC is not 0%, otherwise charge battery.
<p>Unable to communicate with inverter</p>	<ol style="list-style-type: none"> 1. Make sure the connection of communication cable and power cable is correct, refer to the chapter of connection of cable and power; 2. Make sure the address dial code of the master controller connected to inverter is 1; 3. Make sure the inverter dial code of the master controller connected to inverter is correct, refer to the chapter of inverter dial code; 4. If you are using a pin order select box, please verify that the dialing switch is configured correctly.
<p>Unable to be charged by inverter</p>	<ol style="list-style-type: none"> 1. Make sure power cable connection is correct; 2. Check whether inverter has faults; 3. Check whether grid or PV is available; 4. Make sure Time of Use of the inverter setting is correct; 5. Make sure charging voltage and charging current setting of the inverter match the parameters of the battery; 6. Check the battery low or high temperature protection alarm; 7. Check the over current protection alarm; 8. Make sure the SOC value is below 96% (default value).
<p>Unable to discharge while SOC is not zero.</p>	<ol style="list-style-type: none"> 1. Make sure the connection of cables is correct and circuit breaker is ON; 2. Check whether inverter has faults; 3. Make sure the inverter setting is not in back up mode; 4. Check whether SOC is lower than the shutdown value of the inverter; 5. Check the battery low or high temperature protection alarm; 6. Check the over current protection alarm.
<p>SOC value change instantly.</p>	<ol style="list-style-type: none"> 1. It is normal that the SOC value will change when the number of parallel modules changes; 2. It is normal that the SOC value will be calibrated when the battery has been fully charged, or deeply discharged.
<p>Error or Alarm shown on the screen</p>	<ol style="list-style-type: none"> 1. Check the battery. Refer to the definition of the error or warning codes. If you cannot determine the cause of the error.

6.3 Status Code

The following status codes are displayed on the cloud platform.

6.3.1 Warning Codes

Code	Warning type	Investigation & troubleshooting
W1	Battery cell undervoltage alarm	1. Low voltage level and needs to be charged.
W2	Charge overcurrent alarm	1. Restore to factory setting; 2. Make sure the inverter's setting of max current does not exceed the max charge current of the battery.
W3	Discharge overcurrent 1 alarm	1. Make sure the power of load does not exceed the power of battery.
W4	High charge temp alarm	1. Make sure the battery's temperature shown on the inverter or the app is below 55°C, otherwise turn off the battery until the temperature is below 55°C, and then try to charge battery.
W5	High discharge temp alarm	1. Make sure the battery's temperature shown on the inverter or the app is below 55°C, otherwise turn off the battery until the temperature is below 55°C, and then try to discharge battery.
W6	Low charge temp alarm	1. Make sure the battery's temperature shown on the inverter or the app is above 0°C, otherwise turn off the battery until the temperature is above 0°C, and then try to charge battery.
W7	Low discharge temp alarm	1. Make sure the battery's temperature shown on the inverter or the app is above -20°C, otherwise turn off the battery until the temperature is above -20°C, and then try to charge battery.
W8	High ambient temp alarm	1. Make sure the ambient temperature of the battery is below 50°C.
W9	High voltage difference alarm	1. Restart the battery, and if error code W9 still remains or reappears, contact your installer.
W11	High main DC busbar temp alarm	1. Restart the battery, and if error code W11 still remains or reappears, contact your installer.
W12	Low insulation resistance alarm	1. Restart the battery, and if error code W12 still remains or reappears, contact your installer.
W13	Low total voltage alarm	1. Low voltage level and needs to be charged
W14	Low ambient temp alarm	1. Make sure the ambient temperature of the battery is above -25°C.

W15	High MOS temp alarm	1. Reduce the ambient temperature and restart the battery.
W16	Battery cell overvoltage alarm	1. High voltage level and needs to be discharged.
W17	High total voltage alarm	1. High voltage level and needs to be discharged.
W18	Low SOC alarm	1. Low SOC and needs to be charged.
W22	Positive connector high temp alarm	1. Restart the battery, and if error code W22 still remains or reappears, contact your installer.
W23	Negative connector high temp alarm	1. Restart the battery, and if error code W23 still remains or reappears, contact your installer.
W24	Relay high temp alarm	1. Restart the battery, and if error code W24 still remains or reappears, contact your installer.
W25	Positive high temp alarm for docking terminal	1. Restart the battery, and if error code W25 still remains or reappears, contact your installer.
W26	Negative high temp alarm for docking terminal	1. Restart the battery, and if error code W26 still remains or reappears, contact your installer.
W27	Positive high temp alarm for discharge port	1. Restart the battery, and if error code W27 still remains or reappears, contact your installer.
W28	Negative high temp alarm for discharge port	1. Restart the battery, and if error code W28 still remains or reappears, contact your installer.
W400	PCS disconnection	1. Restart the battery, and if error code W400 still remains or reappears, contact your installer.

6.3.2 Error Codes

Code	Error Type	Investigation & troubleshooting
F100	The main control discharge relay is faulty	1. Restart the battery, and if error code F100 still remains or reappears, contact your installer.
F101	The main control charge relay is faulty	1. Restart the battery, and if error code F101 still remains or reappears, contact your installer.
F102	Battery cell fault	1. Restart the battery, and if error code F102 still remains or reappears, contact your installer.
F103	NTC fault	1. Restart the battery, and if error code F103 still remains or reappears, contact your installer.
F104	Current sensor fault	1. Restart the battery, and if error code F104 still remains or reappears, contact your installer.
F105	Master and pack communication lost	1. Restart the battery, and if error code F105 still remains or reappears, contact your installer.
F106	Short circuit fault	1. Make sure the external connection for both battery and inverters are proper; 2. Disconnect all external connections and restart the battery, and if error code F106 still, contact your installer.
F107	Internal total voltage detection fault	1. Restart the battery, and if error code F107 still remains or reappears, contact your installer.
F108	Heating fault	1. Restart the battery, and if error code F108 still remains or reappears, contact your installer.
F109	Battery module conflict	1. Restart the battery, and if error code F109 still remains or reappears, contact your installer.
F110	Cluster address conflict	1. Restart the battery, and if error code F110 still remains or reappears, contact your installer.
F111	Charge MOS fault	1. Restart the battery, and if error code F111 still remains or reappears, contact your installer.
F112	Discharge MOS fault	1. Restart the battery, and if error code F112 still remains or reappears, contact your installer.
F113	Addressing failure	1. Restart the battery, and if error code F113 still remains or reappears, contact your installer.

F114	Precharge fault	1. Restart the battery, and if error code F114 still remains or reappears, contact your installer.
F115	Cluster disconnection	1. Restart the battery, and if error code F115 still remains or reappears, contact your installer.
F116	Battery reverse connection fault	1. Restart the battery, and if error code F116 still remains or reappears, contact your installer.
F117	External total voltage detection fault	1. Restart the battery, and if error code F117 still remains or reappears, contact your installer.
F118	Address non-1 fault	1. Restart the battery, and if error code F118 still remains or reappears, contact your installer.
F119	Address break-sign failure	1. Restart the battery, and if error code F119 still remains or reappears, contact your installer.
F120	Pack disconnect fault	1. Restart the battery, and if error code F120 still remains or reappears, contact your installer.
F123	Microelectronic fault	1. Restart the battery, and if error code F123 still remains or reappears, contact your installer.
F124	Smoke sensor fault	1. Restart the battery, and if error code F124 still remains or reappears, contact your installer.
F125	The number of slave voltage strings does not match	1. Restart the battery, and if error code F125 still remains or reappears, contact your installer.
F126	Temp NTC short circuit of master relay	1. Restart the battery, and if error code F126 still remains or reappears, contact your installer.
F127	Temp NTC open circuit of master relay	1. Restart the battery, and if error code F127 still remains or reappears, contact your installer.
F128	Temp NTC short circuit of master DC busbar	1. Restart the battery, and if error code F128 still remains or reappears, contact your installer.
F129	Temp NTC open circuit of master DC busbar	1. Restart the battery, and if error code F129 still remains or reappears, contact your installer.
F130	Master and EMS communication lost	1. Restart the battery, and if error code F130 still remains or reappears, contact your installer.

F132	EMS SN is empty	1. Restart the battery, and if error code F132 still remains or reappears, contact your installer.
F133	Master SN is empty	1. Restart the battery, and if error code F133 still remains or reappears, contact your installer.
F134	Pack SN is empty	1. Restart the battery, and if error code F134 still remains or reappears, contact your installer.
F136	Relay voltage fault	1. Restart the battery, and if error code F136 still remains or reappears, contact your installer.
F200	Battery cell undervoltage safety lock	1. Restart the battery, and if error code F200 still remains or reappears, contact your installer.
F201	Battery cell high voltage safety lock	1. Restart the battery, and if error code F201 still remains or reappears, contact your installer.
F202	Charge high temp safety lock	1. Restart the battery, and if error code F202 still remains or reappears, contact your installer.
F203	Charge low temp safety lock	1. Restart the battery, and if error code F203 still remains or reappears, contact your installer.
F204	Discharge high temp safety lock	1. Restart the battery, and if error code F204 still remains or reappears, contact your installer.
F205	Discharge low temp safety lock	1. Restart the battery, and if error code F205 still remains or reappears, contact your installer.
F206	Charge overcurrent safety lock	1. Restart the battery, and if error code F206 still remains or reappears, contact your installer.
F207	Discharge overcurrent safety lock	1. Restart the battery, and if error code F207 still remains or reappears, contact your installer.

6.3.3 Protection Codes

Code	Error Type	Investigation & troubleshooting
P1	Battery cell undervoltage protection	1. Low voltage level and needs to be charged.
P2	Overcurrent charge protection	1. Restore to factory setting; 2. Make sure the inverter's setting of max current does not exceed the max charge current of the battery.
P3	Overcurrent discharge protection	1. Make sure the power of load does not exceed the power of battery.
P4	High charge temp protection	1. Make sure the battery's temperature shown on the inverter or the app is below 55°C, otherwise turn off the battery until the temperature is below 55°C, and then try to charge battery.
P5	High discharge temp protection	1. Make sure the battery's temperature shown on the inverter or the app is below 55°C, otherwise turn off the battery till the temperature is below 55°C, and then try to discharge battery.
P6	Low charge temp protection	1. Make sure the battery's temperature shown on the inverter or the app is above 0°C, otherwise turn off the battery till the temperature is above 0°C, and then try to charge battery.
P7	Low discharge temp protection	1. Make sure the battery's temperature shown on the inverter or the app is above -20°C, otherwise turn off the battery till the temperature is above -20°C, and then try to charge battery.
P8	High ambient temp protection	1. Make sure the ambient temperature of the battery is below 50°C.
P9	Excessive voltage difference protection	1. Restart the battery, and if error code P9 still remains or reappears, contact your installer.
P10	Excessive temp of main control relay	1. Reduce the ambient temperature, and restart the battery.
P11	Overtemp protection of master DC busbar	1. Reduce the ambient temperature, and restart the battery.
P12	Low insulation resistance protection	1. Restart the battery, and if error code P12 still remains or reappears, contact your installer.
P13	Low total voltage protection	1. Low voltage level, and needs to be charged.
P14	Low ambient temp protection	1. Make sure the ambient temperature of the battery is above -25°C.

P15	High MOS temp protection	1. Reduce the ambient temperature, and restart the battery.
P16	Battery cell overvoltage protection	1. High voltage level, and needs to be discharged.
P17	High total voltage protection	1. High voltage level, and needs to be discharged.
P18	Low SOC protection	1. Low voltage level, and needs to be charged.
P19	Overcurrent discharge 2 protection	1. Make sure the power of load does not exceed the power of battery.
P22	Positive connector high temp protection	1. Reduce the ambient temperature, and restart the battery.
P23	Negative connector high temp protection	1. Reduce the ambient temperature, and restart the battery.
P24	Relay high temp protection	1. Reduce the ambient temperature, and restart the battery.
P25	Positive high temp protection for docking terminal	1. Reduce the ambient temperature, and restart the battery.
P26	Negative high temp protection for docking terminal	1. Reduce the ambient temperature, and restart the battery.
P27	Positive high temp protection for discharge port	1. Reduce the ambient temperature, and restart the battery.
P28	Negative high temp protection for discharge port	1. Reduce the ambient temperature, and restart the battery.
P30	Charger overvoltage protection	1. Restart the battery, and if error code P30 still remains or reappears, contact your installer.

P/N: 118.601.00.0113



Installation Video:



CEC List Checking:



UL 9540:



Product Specifications:



Renon Smart connection Guide:



Renon Power Technology Inc.

5900 Balcones Drive Suite 100, Austin, TX 78731 USA

Renon Power Solutions Sp.z o.o.

ul. ELBLĄSKA 1, 93-459, ŁÓDŹ, POLAND

Renon Power Technology B.V.

Rietbaan 10, 2908 LP Capelle aan den IJssel

Renon Power 株式会社

東京都中央区日本橋箱崎町 20-5 VORT 箱崎 5F



Whatsapp



Linkedin



Website